



FBM 4100 Series

EN User manual

EN EU Declaration of Conformity



01.	Product information.....	4
02.	Safety instructions.....	5
03.	Safety.....	6
04.	Technical specifications.....	10
05.	Acceptance, transport and storage.....	15
06.	Preparation.....	15
07.	Assembly.....	17
08.	Commissioning.....	20
09.	Menu.....	24
10.	Switch motor on/off.....	25
11.	Speed setting.....	25
12.	Dry-run protection.....	26
13.	Batch filling.....	28
14.	Interface.....	30
15.	Lighting control.....	30
16.	Device information.....	31
17.	Temperature-performance adjustment.....	33
18.	Decommissioning.....	34
19.	Disassembly.....	34
20.	Cleaning.....	37
21.	Maintenance and repair.....	37
22.	Troubleshooting.....	38
23.	Recycling.....	39
24.	EU Standards.....	40
25.	EU Directives.....	40

1. Product information

The operating instructions enable safe and efficient handling of the battery motor of the series:

FBM 4 100

The operating instructions are an integral part of the Battery Motor. They must be kept in the immediate vicinity of the personnel and be accessible at all times. The personnel must have carefully read and understood these operating instructions before starting any work.

This operating manual may only be used with the express permission of FLUX-GERÄTE GMBH. be reproduced, translated or made available to third parties.

This is the original operating manual.

Copyright © 2026 FLUX-GERÄTE GMBH
Subject to technical changes.

1.1 Manufacturer

FLUX-GERÄTE GMBH
Talweg 12
75433 Maulbronn
Germany

Tel.: +49 (0)7043 101-0
Fax: +49 (0)7043 101-555
Email: export@flux-pumpen.de

Ordering and customer service

You can find your direct contact person for ordering and customer service in the contact section of the FLUX website.

Contact section of the FLUX website:

<https://www.flux-pumps.com/en-DE/contact.html>

Or via QR code:



1.2 Liability, warranty and guarantee

The operator assumes operational responsibility upon acceptance of the product. The warranty period is 12 months from the date of delivery. The warranty is provided in accordance with our general terms and conditions of sale and delivery are only accepted by:

- Intended use of the product as described in these operating instructions.
- Proper and correct installation, commissioning and operation.
- Repairs may only be carried out by authorised specialist personnel.
- Exclusive use of original spare parts.

The safety instructions highlighted in this operating manual must be observed in all cases. FLUX-GERÄTE GMBH accepts no liability for damage or malfunctions resulting from failure to observe the operating instructions. The manufacturer's warranty shall be void in the event of damage or malfunctions attributable to unauthorised modifications or alterations to the delivered device. Wear parts are not covered by the warranty. Wear and tear occurs due to wear and tear on the device.

1.3 Returns

In order for returns to be processed, an RMA slip must be requested and sent to FLUX-GERÄTE GMBH together with the RMA number and the product.

RMA = Return Merchandise Authorisation

The RMA process is described on the FLUX website at the following link:

<https://www.flux-pumps.com/en-DE/service.html>

Or via QR code:



1.4 Required documents

The documents listed in the appendix to these operating instructions, such as the EU Declaration of Conformity, are included in the scope of delivery and must be observed. If this operating manual contains documentation from suppliers (as an appendix), FLUX-GERÄTE GMBH accepts no liability or warranty for its content.

The Battery Motor may only be put into operation once all documentation has been read and understood.

1.5 Presentation of information

To simplify and ensure safe working with this operating manual, uniform safety notes, symbols, terms and abbreviations are used. These elements are explained in the following sections for better understanding.

2. Safety instructions

Safety instructions warn of damage to property and personal injury. The measures described for averting danger must be observed. The safety and warning instructions in this document indicate dangers and risks. They are designed in accordance with the EN ISO 7010 and EN ISO 12100 series of standards.

2.1 Symbols

Different symbols and highlights make this document easier to read.

The symbols and highlights have the following meanings:

Description
- Listing
o Subitem of a list
▪ Instructions without sequence
1. Instructions with sequence
➤ Measure
✓ Successfully completed
⚠ Warning notice in the text

2.2 Structure

⚠ SIGNAL WORD

Nature and source of the hazard!

Consequences of non-compliance.

- Consequences of non-compliance!
- ▶ Measures to prevent this!

Safety instructions have the following meanings:

Signal word:

Indicates the severity of the hazard.

Warning sign:

Draw attention to the danger.

Nature and source of the hazard:

Describes the causes of the hazard.

Consequence:

Describes the consequences of non-compliance.

Action:

List measures to avoid the danger.

⚠ DANGER

EN-10000

This warning indicates a high-risk hazard
that could result in death or serious injury!

⚠ WARNING

EN-20000

This warning indicates a medium-risk hazard
that could result in death or serious injury!

⚠ CAUTION

EN-30000

This warning indicates a low-risk hazard **that may result in minor or can lead to moderate injury!**

💡 NOTE

DE-40000

This notice contains information about possible
Property damage or environmental damage
that does not result in personal injury!

3. Safety

The engine has been manufactured in accordance with generally accepted technical standards. Nevertheless, there is a risk of damage to property and personal injury if the safety instructions are not observed.

The engine may only be used if it is in perfect working order. The operating instructions must be observed. The operator must use the engine in accordance with its intended purpose and in a safe and hazard-conscious manner.

Unauthorised modifications to the engine will invalidate the warranty.

Although this is a battery-powered motor, the warning and safety instructions only refer to the term "motor" for ease of understanding.

3.1 Warning notices

 Always wear personal protective equipment (PPE) when carrying out any work!



3.1.1 Danger

DANGER EN-10019

Your own responsibility!

In the event of improper use and the operator shall be liable for any resulting hazards and injuries, including fatalities.

- ▶ Only use the motor for its intended purpose and read the instructions carefully!

DANGER EN-10020

Risk of cuts!

Risk of injury from loose drive pin.

- Never operate motors without a pump.
- ▶ Never put your fingers in the driver!

DANGER EN-10024

Danger of explosion if used improperly!

Incorrect handling of the battery (e. g. short circuit, overheating) may result in explosion or fire.

- ▶ Only use approved batteries.
- ▶ Never open or store above 45°C!

DANGER EN-10014

Death by bludgeoning!

When the container is empty, the motor and pump may become heavier than the container itself.

- If the container is placed on a shelf, it may tip forward and fall off.
- ▶ Secure and fasten containers!

DANGER EN-10003

Falling load!

The motor may come loose due to its own starting torque.

- Engines are very heavy and can cause serious injury if they fall.
- Check the fit of the motor.
- ▶ Only start the motor once the union nut has been tightened securely!

DANGER EN-10015

External damage!

Damage to the pump, motor and hose can result in personal injury and environmental damage.

- Check the pump, motor and hose for possible damage before each use.
- Repair damage immediately.
- ▶ Only put back into operation after repair!

DANGER EN-10007

Increased pressure!

Containers and hoses may burst at high operating pressures. Hoses may become detached.

- Serious injury possible.
- Watch out for flying debris.
- ▶ Avoid excess pressure when filling a container!

DANGER EN-10011

Contact with liquids! (I)

An accident at work or improper use may result in liquid escaping and coming into contact with people.

- Classify how dangerous the liquid is.
- Observe internal company instructions.
- Be mindful of people in the vicinity.
- ▶ Always wear protective clothing!

⚠ DANGER EN-10012

Contact with liquids! (II)

After switching off, liquid remains in the pump tube and hose, which can flow out uncontrollably.

- Fill carefully and at a reasonable speed to prevent liquids from splashing out.
- Allow the hand nozzle to drip dry after filling.
- Remove spilled liquid in general and dispose of it in an environmentally friendly manner.
- ▶ Always wear protective clothing!

⚠ DANGER EN-10013

Contact with liquids! (III)

Trapped air can be forced back into the container. This may cause the liquid to spray out.

- Before starting the engine, open the connected valves fully.
- ▶ Always wear protective clothing!

3.1.2 Warning

⚠ WARNING EN-20001

Risk of crushing!

The motor shifts the pump's centre of gravity to the motor side.

- The pump may tip over and fall with the motor.
- ▶ Secure the pump appropriately to prevent it from tipping over!

⚠ WARNING EN-20003

Property damage and personal injury!

Failure to observe the safety instructions may result in injury to persons and damage to the environment, as well as damage to the motor and pump!

- ▶ Read all safety instructions!

⚠ WARNING EN-20010

Incorrect use!

Before starting up, please also read the operating instructions for the pump and Accessories used.

- Read all documents!
- ▶ Observe all safety instructions!

⚠ WARNING EN-20007

Risk of getting stuck!

Loose clothing, hair or jewellery may become caught in rotating parts.

- ▶ Wear protective clothing, tie back long hair, remove jewellery!

⚠ WARNING EN-20005

Fire hazard!

Risk of injury and fire due to electrical energy.

- The Battery Motor and battery must not be opened.
- Remove the battery before performing any work.
- ▶ Short circuit, overheating and fire hazard if the battery is damaged.

⚠ WARNING EN-20006

Danger from rotating components!

Touching rotating clutch parts during operation can result in serious injury.

- Do not touch any rotating parts during operation.
- ▶ Only switch on the motor after it has been installed on a pumping station!

⚠ WARNING EN-20008

Improper installation!

Incorrectly fitted pumps or adapters may come loose during operation and cause injury.

- Only use original accessories.
- ▶ Carry out assembly according to the instructions and check!

⚠ WARNING EN-20009

Hot surface!

The motor body may become hot during operation (over 60°C).

- Allow to cool before touching.
- ▶ Wear protective gloves!

3.1.3 Caution

CAUTION EN-300 13

Loss of warranty!

To be eligible for warranty or repairs, the motor must only be used as described in these instructions.

- The warranty shall be void in the event of improper use.
- ▶ Only use the motor for its intended purpose!

CAUTION EN-300 14

Watch out for damage!

Visually inspect the coupling on the pump and the driver on the engine for signs of wear.

- Replace the coupling and driver.
- ▶ Do not use if damaged beyond repair!

CAUTION EN-300 15

Untrained personnel!

Despite its ease of use, the motor must not be operated without instruction.

- The operator must be instructed before operating the engine.
- ▶ Ensure that the operator has read and understood the operating instructions!

3.1.4 Note

NOTE EN-40002

Defective parts!

Always replace defective parts!

3.1.5 Recommendation

The following information represents recommendations from FLUX-GERÄTE GMBH and is intended to ensure optimal use and safe handling of the motor.

CAUTION EN-300 10

Recommendation:

Only use original spare parts and Accessories from FLUX!

NOTE EN-40003

Recommendation:

The lifespan of our products is significantly extended through proper handling, regular maintenance and cleaning!

NOTE EN-40004

Recommendation:

Electrical equipment must be inspected regularly by a qualified electrician, e.g. in accordance with DGUV Regulation 3. The operator is responsible for this.

3.2 Intended use

The Battery Motor is intended exclusively for its intended use and may only be operated in accordance with the functions and limits described in these instructions.

- The Battery Motor is designed for mobile, mains-independent use for pumping, decanting and emptying liquids.
- Operation exclusively in conjunction with suitable pumps, in particular the Drum and container pumps (Series 400).
- Third-party pumps may only be used in conjunction with the FLUX competition adapter.
- Other third-party devices may only be used if they have been approved by us.
- Use via manual control.
- Remote control via peripherals.
- Use only by trained personnel.
- Intended exclusively for commercial use.
- Not for private use.
- Only approved 18V lithium-ion batteries from the manufacturer Einhell may be used.

3.3 Improper use

- ⊘ Operation in potentially explosive atmospheres.
- ⊘ Transferring flammable liquids.
- ⊘ Use with unauthorised accessories or batteries.
- ⊘ Unauthorised modifications to the device.
- ⊘ Use by untrained or uninstructed personnel.
- ⊘ Operation with open housing.

3.4 Predictable misuse

Any use beyond this is considered foreseeable misuse and may result in danger to persons or the environment. In addition, damage to property and equipment may occur.

3.4.1 Use cases

The following use cases constitute foreseeable misuse of the Battery Motor:

- ⚠ Use in potentially explosive atmospheres.
- ⚠ Use with incompatible or unauthorised devices.
- ⚠ Manipulation of the electronics, display or software, for example to change the motor speed, encoder calibration or other control parameters.
- ⚠ Operation with unsuitable batteries (e. g. batteries with different voltage, capacity or design) that have not been approved by the manufacturer.
- ⚠ Bypassing safety functions, such as temperature or overload shutdown.
- ⚠ Use in extreme environmental conditions, such as excessive humidity, dust, temperatures outside the permissible operating limits.
- ⚠ Mechanical alterations to the housing, threaded connection or battery guide.
- ⚠ General misuse of the device.
- ⚠ Contact with aggressive or chemically reactive substances that may cause undesirable reactions with components or batteries (e. g. corrosion, gas formation, material embrittlement).

3.4.2 Consequences

Predictable misuse can lead to the following risks:

- ⚠ Risk of serious injury due to electric shock, burns or mechanical impact.
- ⚠ Damage to the device and loss of functionality.
- ⚠ Expiry of guarantee and warranty claims.
- ⚠ Environmental damage, especially if the batteries are handled or disposed of improperly.
- ⚠ The operator is obliged to prevent any foreseeable misuse and to instruct users accordingly.

4. Technical specifications

FBM 4100 Battery Motor	
Type of motor	Brushless DC motor (BLDC)
Rated power ventilated (Core, Pro)	420 W
Rated power closed (Core A, Pro A)	260 W
Rotational speed [min ⁻¹]	5.500–12.250
Speed control	10-Step adjustable
Rating with battery cover	IP24/IP44 (A)
Connection for peripherals	24 V
Battery compartments	2
Total nominal voltage	36V DC
Weight (without batteries)	1.6 kg
Weight (with batteries)	2.8 kg
Permissible ambient temperatures	
In operation	0°C to 40°C

Battery B40-4100	
Design	Lithium-ion
Rated voltage	18 V
Rated capacity	4 Ah
Rating	IP57, sealed
Dimensions [mm]	130 x 82 x 51
Weight	580 g
Permissible ambient temperatures	
In operation	0°C to 50°C
When storing	0°C to 30°C

Charger BCH-4100	
Mains voltage	220–240 V
Mains frequency	50–60 Hz
Output voltage	18 V
Output current	3 A
Dimensions [mm]	225 x 90 x 225
Weight	830 g
Charging time	75 minutes
Permissible ambient temperatures	
In operation	0°C to 40°C
When storing	0°C to 30°C

4.1 Models and Accessories

Battery Motor models	
FBM 4100 Core, ventilated housing, without interface connection	10-40100001
FBM 4100 Pro, ventilated housing, with interface connection	10-40100000
FBM 4100 Core A, closed housing, without interface connection	10-40100003
FBM 4100 Pro A, closed housing, with interface connection	10-40100002

Battery Motor sets	
FBM 4100 Core, 2× 18 V / 4 Ah Li-ion battery, charger 220-240 V / 50-60 Hz	10-40100004
FBM 4100 Pro, 2× 18 V / 4 Ah Li-ion battery, charger 220-240 V / 50-60 Hz	10-40100005
FBM 4100 Core A, 2× 18 V / 4 Ah Li-ion battery, charger 220-240 V / 50-60 Hz	10-40100006
FBM 4100 Pro A, 2× 18 V / 4 Ah Li-ion battery, charger 220-240 V / 50-60 Hz	10-40100007
FBM 4100 Core, 2× 18 V / 4 Ah Li-ion battery	10-40100008
FBM 4100 Pro, 2× 18 V / 4 Ah Li-ion battery	10-40100009
FBM 4100 Core A, 2× 18 V / 4 Ah Li-ion battery	10-40100010
FBM 4100 Pro A, 2× 18 V / 4 Ah Li-ion battery	10-40100011

Accessories	
Charger BCH-4100, 220-240 V, 50-60 Hz	10-40102001
Battery B40-4100, 18 V, 4 Ah, sealed	10-40102003
Battery cover	10-40105014
Competition adapter	10-95906284

4.2 Device description

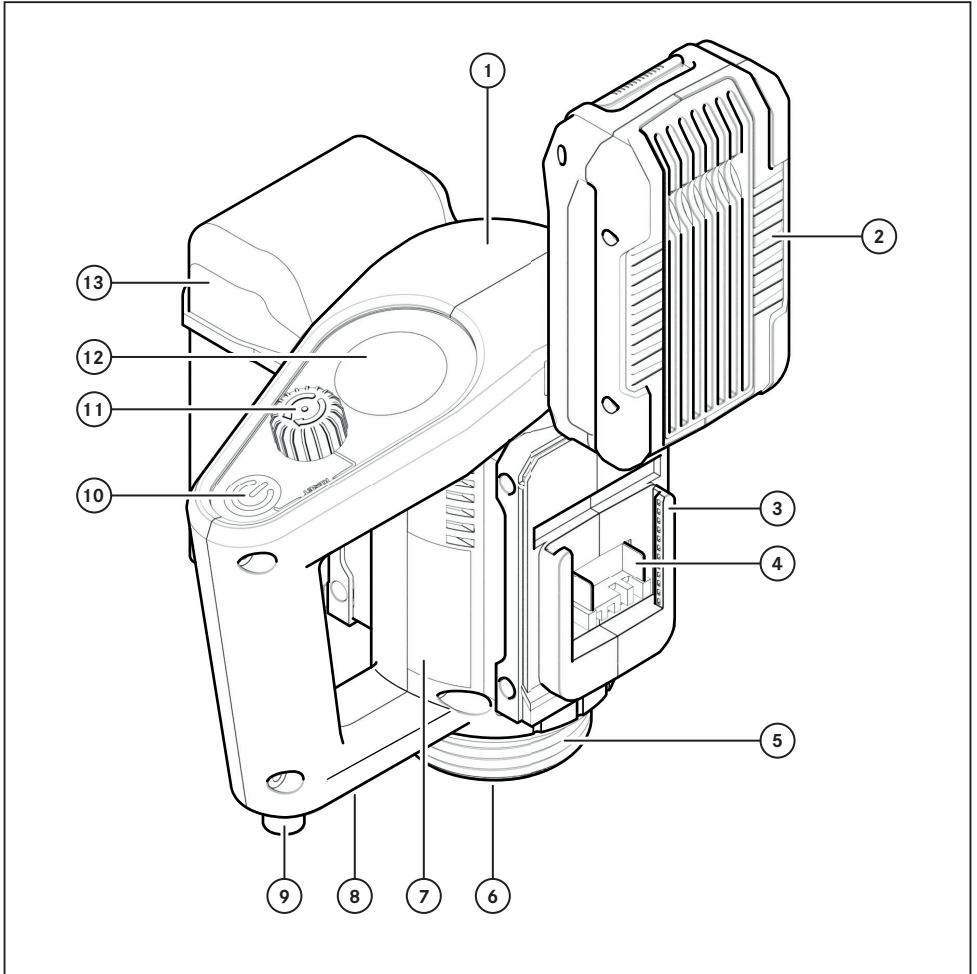

No.	Description	No.	Description
①	Engine casing	⑧	LED light
②	Lithium-ion batteries	⑨	5-pin interface connector (Pro models only)
③	Battery compartment	⑩	Power button
④	Contact elements	⑪	Multifunction knob
⑤	Pump pipe connection	⑫	Liquid crystal display
⑥	Driver	⑬	Battery cover
⑦	Nameplate		

4.3 Nameplate

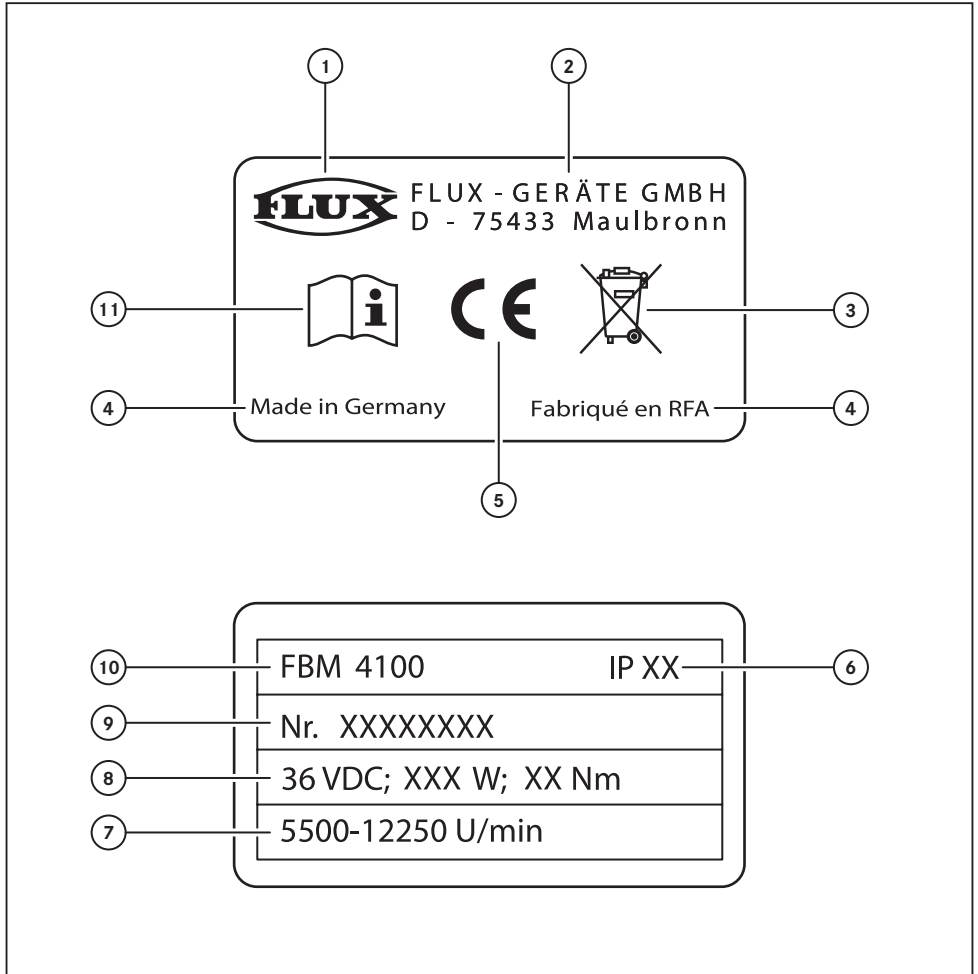

No.	Description	No.	Description
①	FLUX logo	⑦	Speed specification
②	Address	⑧	Engine specifications
③	WEEE labelling	⑨	Serial number
④	Production site	⑩	Product name
⑤	CE marking	⑪	Note on observing the operating instructions
⑥	Rating		

4.4 Interface assignment

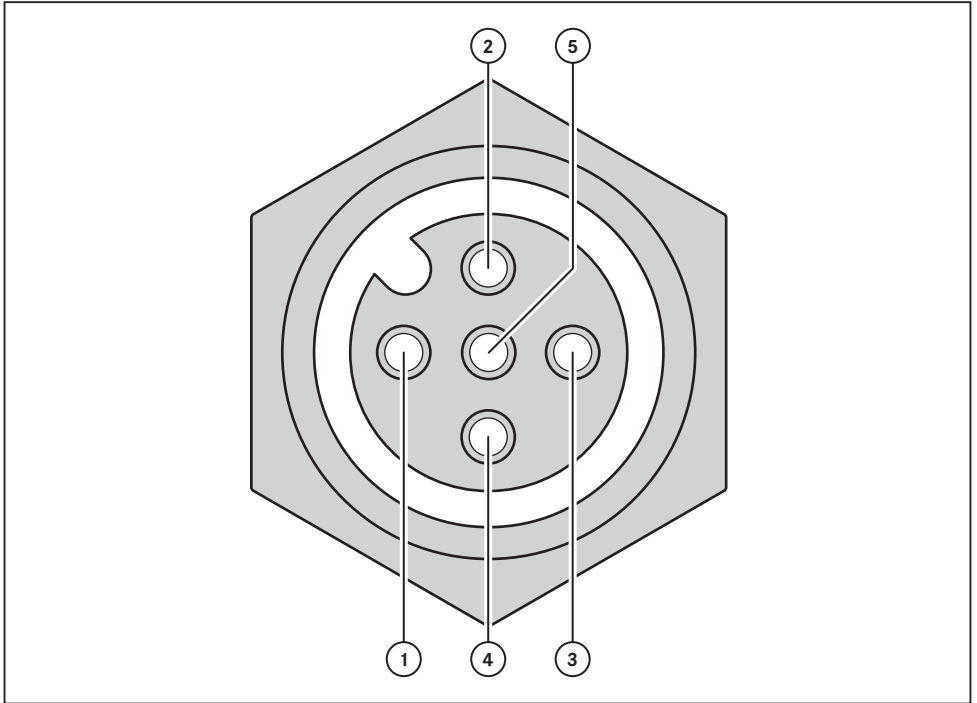

No.	Pin	Signal / Function	Description
①	1	External I/O button	Input for external push button or control signal
②	2	PNP/NPN	Switching logic against GND (pin 5) and/or against +24 V (pin 4)
③	3	S1 FLUXTRONIC®	Communication or control signal (FLUXTRONIC® interface)
④	4	+24 V supply	Supply voltage for external devices (max. 100 mA)
⑤	5	GND	Reference potential (0 V)

Note

⚠ The pin assignment shown is a top view of the 5-pin M12 device socket. When assembling the cable, please note that the pin assignment is mirror-inverted to the plug view.

⚠ For correct pin assignment, note the mechanical coding (guide tab) of the plug.

Note

⚠ For safety reasons, the initial start-up should be carried out without any medium in order to prevent possible damage caused by incorrect connection.

5. Acceptance, transport and storage

This chapter describes the measures and requirements that must be observed after receipt of goods. It contains information on the proper acceptance of the product as well as on safe transport and proper storage. Compliance with these specifications ensures safety.

- ⚠ Before transport and storage, observe the safety instructions in Chapter 3.

5.1 Acceptance

The motor is delivered securely in its original packaging.

- Check the delivery for transport damage.
- Check that the delivery is complete.
- Report any transport damage to the shipping company immediately.

- ⚠ Check the scope of delivery in accordance with section 4.1.

5.2 Transport

The compact design of the motor allows for quick and easy switching between different pumps. However, certain risks must be taken into account during transport.

- The motor may only be transported individually.
- The motor must be carried by the handle to prevent it from falling.

5.3 Storage

The motor is robust and durable. To maintain these characteristics in the long term, the motor and batteries must always be stored properly.

- ⚠ Before storage, observe the instructions in Chapter 20 "Cleaning".

- Always store the motor in a dry and dust-free place.
- Store the engine in a clean condition.
- Store the motor without the pump and Accessories.
- Protect from UV radiation.
- Protect from the weather.
- Remove the battery during prolonged storage.

6. Preparation

This chapter explains how to safely and correctly commission the product.

- ⚠ Please read the safety instructions in Chapter 3 before you begin with the preparation and further steps.

6.1 Supported pumps

F 400 Series

F/FP 424 Series

F/FP 425 Series

F 426 Series

F/FP 427 Series

F/FP 430 Series

MINIFLUX Series

F 500 VISCOPOWER Series

F 570 Series

Note

- ⚠ Even when using a pump with an Ex-marking, operation of the Battery Motor in potentially explosive areas is not permitted!

⚠ DANGER

EN-100 17

Danger of explosion!

The motor must not be operated in potentially explosive atmospheres.

- There is a risk of explosion resulting in death!
- ▶ For explosion-proof areas, use only explosion-proof products!

6.2 Charging process

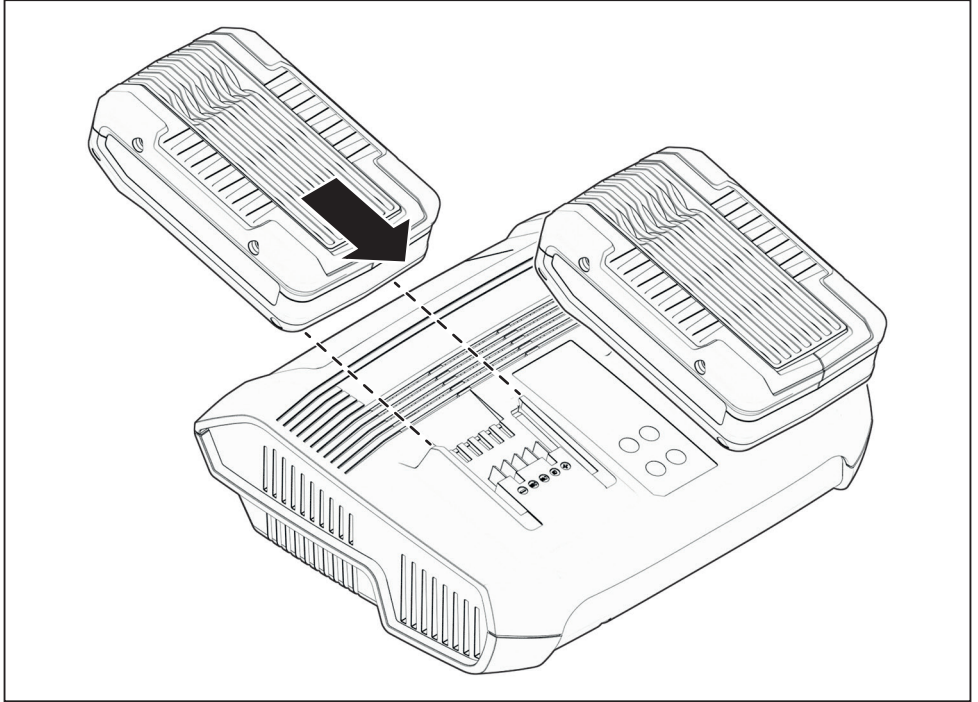

6.3 Recharge batteries

The batteries must be fully charged before installation. Only use the original charger for charging by Einhell.

- ⚠ The charger is a product from Einhell and is supplied with its own supplier documentation. Read all documents and observe all safety instructions!

Step-by-step guide

1. Place the charger on a stable surface.
 2. Plug in the mains plug.
 3. Insert the batteries into the device from above.
 4. LED lamps indicate the charging progress.
- ✓ The charging process is complete.

- ⚠ If problems occur during charging, stop the process immediately and follow the instructions in the operating manual.

6.4 Complete the charging process

Once the batteries are fully charged, they can be removed from the charger.

Step-by-step guide

1. Remove fully charged batteries from the charger.
 2. Disconnect the charger from the mains.
 3. Place both batteries and the motor on a stable surface.
- ✓ The preparation is complete.

7. Assembly

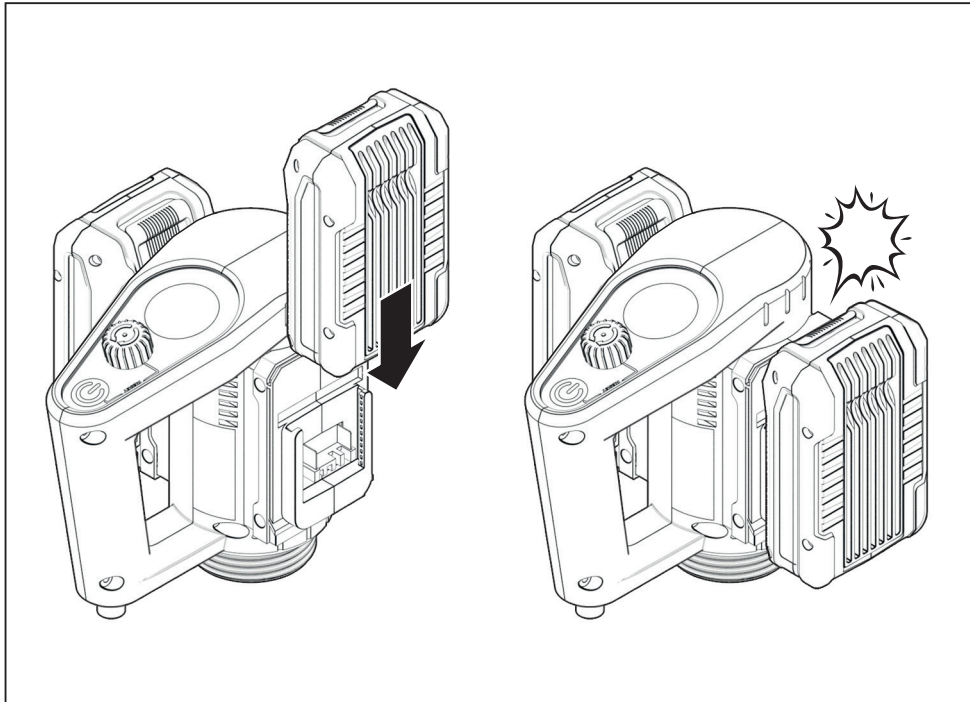

7.1 Installation of the batteries

Once the batteries are fully charged, they can be mounted on the motor according to the instructions.

Step-by-step guide

1. Insert the battery into the left-hand compartment and snap it into place.
 - You will hear a click when it clicks into place.
 2. Insert the battery into the right-hand compartment and snap it into place.
 - You will hear a click when it locks into place.
- ✓ The installation of the batteries is complete.

⚠ If problems arise during assembly, stop immediately and read the instructions again.

7.2 Installing the battery cover

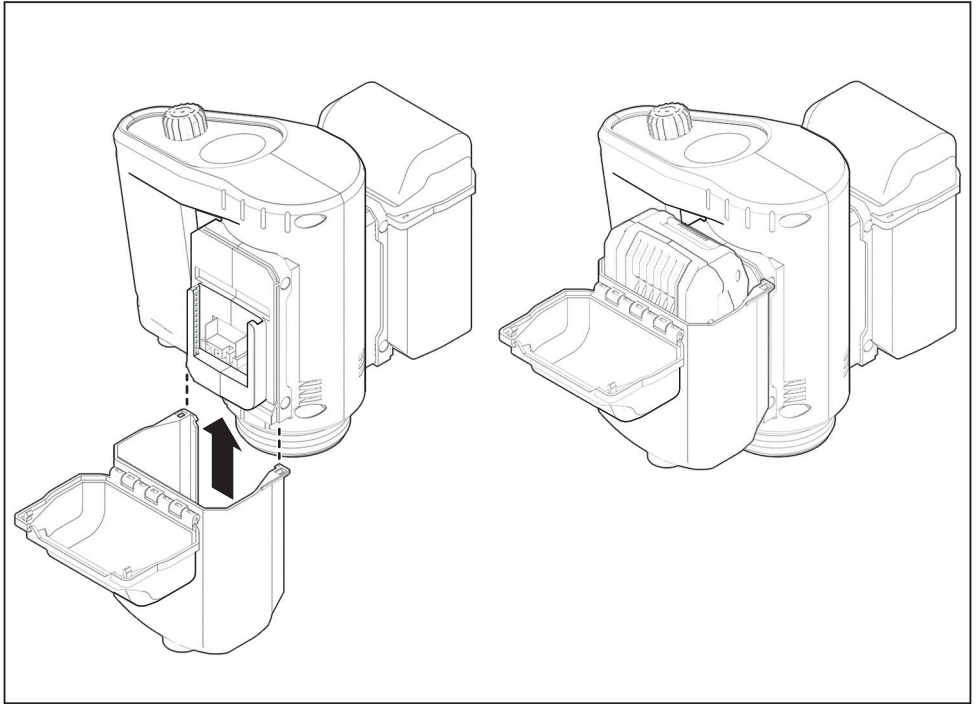

After inserting the batteries, the battery covers can be securely attached as described.

Step-by-step guide

1. Open the battery cover.
 2. Slide the battery cover into the guides from below and snap it into place.
 - The batteries can also be inserted and removed at a later date.
 3. Close the battery cover again.
- ✓ The battery cover is now fully assembled.

Note

- ⚠ Without the battery cover, there is no protection against splashing water.
- ⚠ The specified degree of protection is only achieved when the battery cover is fitted!
Ventilated housing: Rating IP24
Closed housing: Rating IP44
- ⚠ Rating according to DIN EN 60529.

7.3 Engine assembly

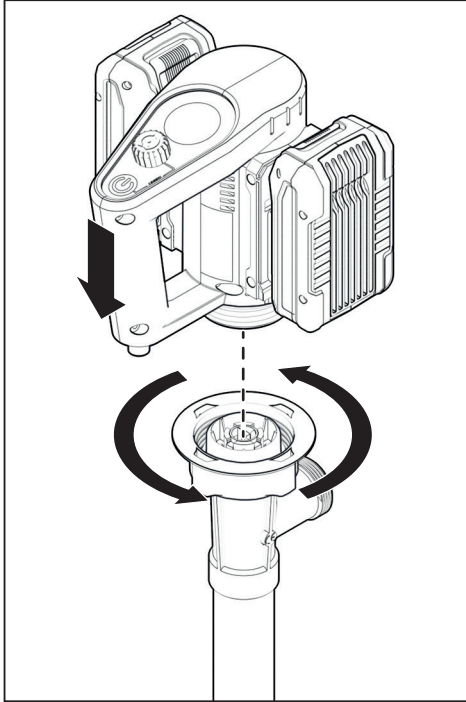

Once all preparatory steps have been completed, the motor can be securely mounted on the motor mount of the pump tube as described.

Step-by-step guide

1. Place the motor on the bearing flange of the pump.
 2. Press the union nut on the pump towards the engine and screw it tightly onto the engine.
- ✓ The installation of the motor is complete.

⚠ If problems arise during assembly, stop immediately and read the instructions again.

8. Commissioning

The Battery Motor is equipped with control software that can be operated independently of the motor. The motor does not need to be switched on to operate the software – control is also possible when the motor is switched off.

This chapter explains each instruction as a step-by-step guide.

8.1 Start software

1. Insert both batteries into the device.
 2. The software starts automatically.
- ✓ The software is ready for use.

8.1.1 Wake up software

The software can be easily awakened from deep sleep mode.

- Press the rotary knob and the power button simultaneously.
- Remove the batteries and reinsert them.

⚠ Same procedure as reset function.

8.2 Switch off software

- Unplug both batteries.
- ✓ The software will be switched off once the process is complete.

8.2.1 Energy-saving mode

After 10 minutes, the backlight switches off to save energy.

8.2.2 Deep sleep mode

After 6 hours, the software switches to deep sleep mode.

8.2.3 Reset function

The software can be quickly restarted using the reset function. All saved profiles are retained.

- Press and hold the rotary knob and the power button simultaneously.
- ✓ The software will restart after the process is complete.

8.3 Main display

The main display shows the battery level, the current speed and all active programmes.

8.3.1 Battery level

The battery level is shown on the main display on both the left and right sides. The respective display shows the charge status of the corresponding battery.

8.3.2 Speed display

The main display shows the current speed using filled dots. The factory setting for the speed is 50%, which is represented by 5 out of 10 filled dots.

This display remains permanently visible.

The speed value is also shown as a percentage.

8.3.3 Programme display

The main display shows all active programmes and their status. If a programme is active, the corresponding symbol is displayed. Information such as the active profile, the number of filling processes and the timer are also shown.

↳ **The following functions are displayed:**

- Dry-run protection
- Batch filling
- Interface assignment
- Active profile
- LED light
- Timer
- Filling operations



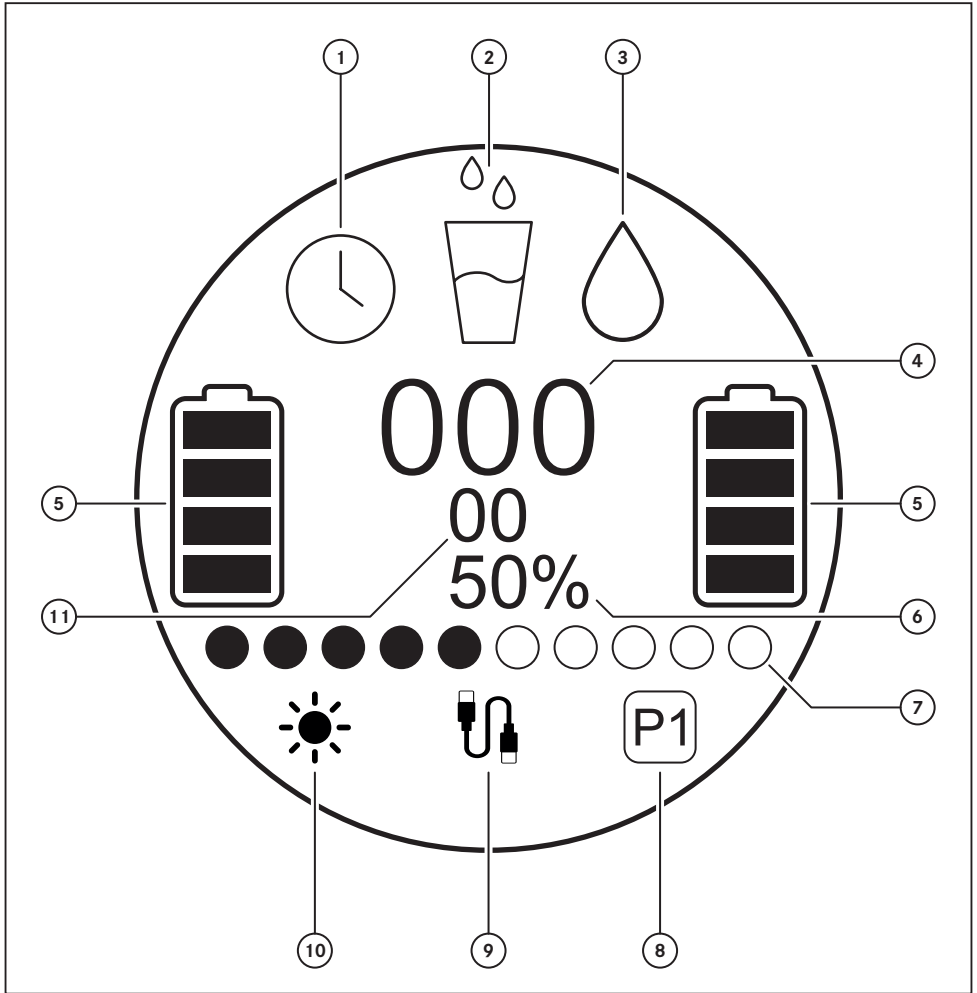



8.4 Overview of the main display







No.	Description	No.	Description
①	Learning mode active	⑦	Speed specification in stages
②	Batch filling active	⑧	Active profile (P1–P6)
③	Dry-run protection active	⑨	Interface active
④	Timer	⑩	LED light active
⑤	Battery charge level	⑪	Number of filling operations
⑥	Speed specification in percent		



Figure: Main display











8.5 Description of symbols



Menu		
Symbol	Description	Chapter
	Dry-run protection	12
	Batch filling	13
	Interface	14
	Lighting control	15
	Device information	16
	Back	9

Dry-run protection		
Symbol	Description	Chapter
	Switch on dry-run protection	12
	Switch off dry-run protection	12

Interface assignment		
Symbol	Description	Chapter
	Switch on interface	14
	Switch off interface	14

Lighting control		
Symbol	Description	Chapter
	Switch on the light	15
	Switch off the light	15

Batch filling		
Symbol	Description	Chapter
	Start learning mode	13
	Confirm teach-in process	13
	Training process successful	13
	Teaching process cancelled	13
	Repeat the teach-in process	13
	Start filling process	13
	Cancel filling process	13
	Overwrite profile	13
	Load profile	13
	Profile memory not in use	13
	Profile memory occupied	13

Device information		
Symbol	Description	Chapter
	System information	16
	Software reset	16
	Digital documentation	16

Temperature-performance adjustment		
Symbol	Description	Chapter
	Temperature limit reached	17

9. Menu

The menu contains all available programmes. The programmes are arranged in a ring menu and can be controlled and selected using the rotary knob. Press Back to exit the menu and return to the main display.

↳ The menu contains the following programmes:

- Dry-run protection
- Batch filling
- Interface assignment
- Lighting control
- Device information
- Back

9.1 Menu navigation

The menu navigation is structured so that all functions and settings are logically organised and easy to find. The rotary knob is the main control element and has two functions:

9.1.1 Press the rotary knob

Confirm your selection or start programmes by pressing the rotary knob.

9.1.2 Turn the knob

By turning the rotary knob, you can navigate through the software and set the speed.

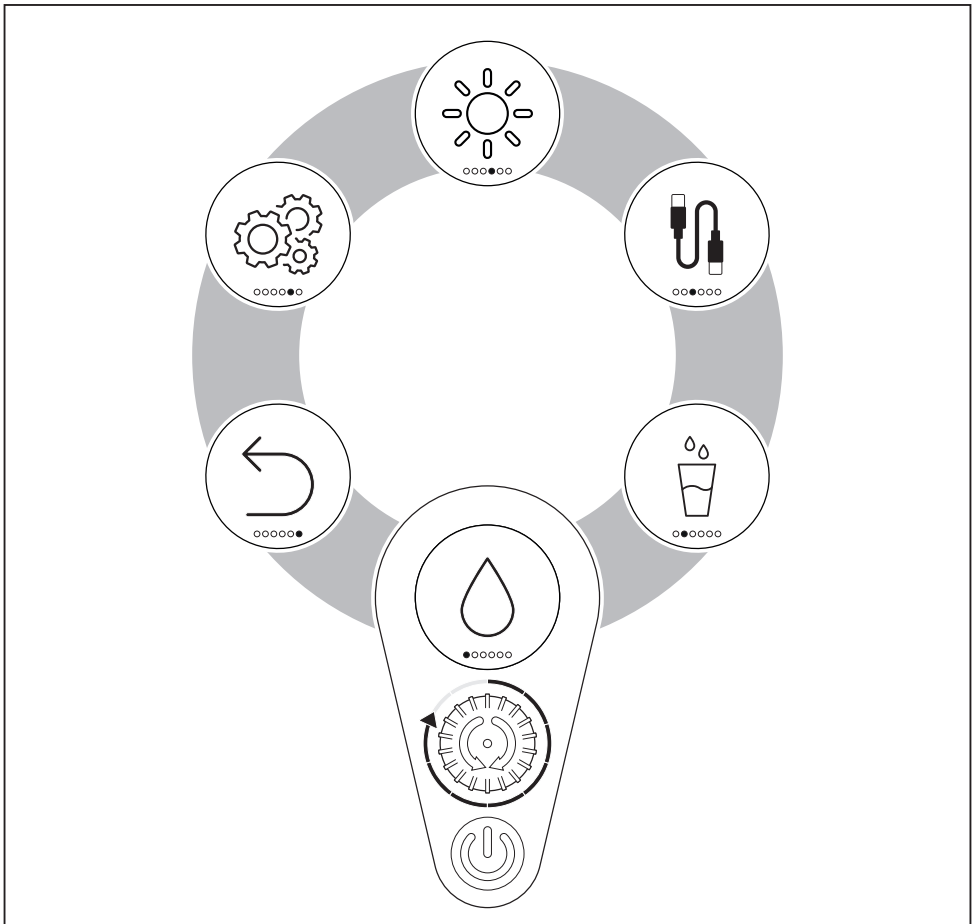

9.2 Exit menu

To exit the menu or a submenu item, use the Back function. This allows you to go back one level in the menu or within a programme at any time.

There are two ways to exit the menu or a programme:

9.2.1 Back

1. Turn the rotary knob (2) until the last menu item is reached.
 2. Once the last menu item has been reached, the back symbol (1) is displayed.
 3. Press the rotary knob (2) to confirm your selection.
- ✓ The menu closes and you return to the main display.

9.2.2 Power button

- Press the power button (3) (<1 second).
- ✓ The menu closes and you return to the main display.

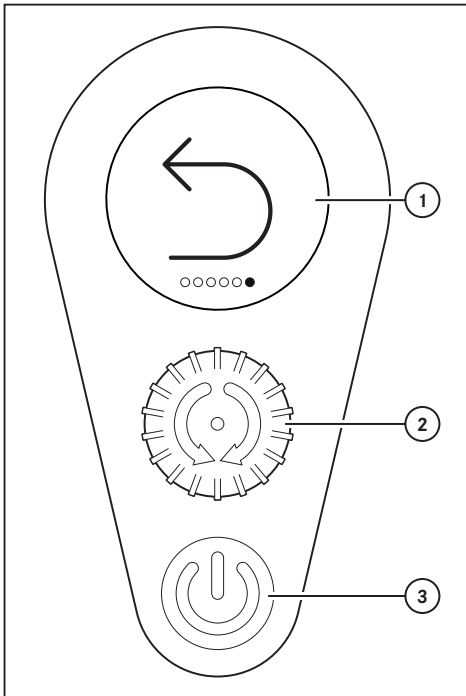

Illustration: Back

10. Switch motor on/off

The engine can be started after the software has been launched. The software remains operable even when the engine is switched off.

- ⚠ Before starting the engine, observe the safety instructions in Chapter 3.

10.1 Start the engine

- Press and hold the power button (1 second).
- ✓ The motor starts and switches to the switched-on state.

10.2 Switch off the engine

- Press the power button.
- ✓ The motor stops and switches to the off state.

11. Speed setting

The speed is controlled by a rotary knob and can be adjusted in 10 steps, each step corresponding to 10%. The default speed setting is 50%. It can be adjusted both before starting the motor and during operation.

The speed is visualised in a ring shape during adjustment, with the ring indicating progress. The current speed value is displayed as a percentage in the centre of the ring. The change is applied immediately and does not need to be confirmed.

If no further input is made, the software automatically hides the speed setting on the panel.

11.1 Increase speed

- Turn the knob clockwise.
- ✓ The speed is increased gradually.

⚠ The maximum speed is 100%.

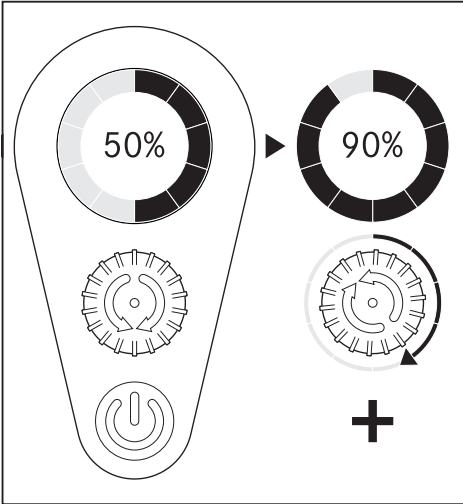

11.2 Reduce speed

- Turn the knob anticlockwise.
- ✓ Speed is gradually reduced.

⚠ The minimum speed is 10%.

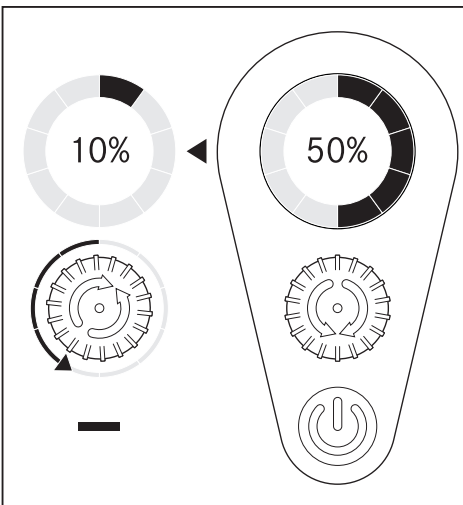

12. Dry-run protection

Dry-run protection is a switchable support feature that prevents a pump from operating without a pumped medium. Dry-run protection extends the service life of the pump used. If a pump runs without liquid (dry running), this can cause damage. A pump that pumps liquid requires more power. If the motor's power consumption drops unexpectedly sharply, this may be an indication of dry running.

When dry-run protection is activated, the motor switches off automatically as soon as the power consumption drops significantly and falls below the threshold value specified during programming.

- ⚠ The dry-run protection is not designed as a safety function, but serves exclusively to assist in the detection of dry running.

Note

- ⚠ The dry-run protection may only be activated if the pump is located in a container filled with medium.
- ⚠ The dry-run protection must not be activated if a pump is used that has both a semi-axial rotor (Z version) and a hand nozzle.

12.1 Switch on dry-run protection

1. Press the rotary knob to open the menu.
 2. Press the rotary knob again to select the dry-run protection.
 3. Press the rotary knob again to activate the dry-run protection.
 4. The main display appears.
 5. Set the speed to the desired value.
 6. The 5-second timer is displayed.
 7. Press the power button to start the engine.
 8. The timer then counts down to 0 seconds.
 9. The display lights up blue and the symbol for Dry-run protection is shown for 3 seconds.
- ✓ The dry-run protection is active.

↳ Status change

- While dry-run protection is active, the dry-run protection symbol is displayed in the menu.

12.1.1 During operation

If the engine is already running, some points in section 12.1 will be skipped.

1. Press the rotary knob to open the menu.
 2. Press the rotary knob again to select the dry-run protection.
 3. Press the rotary knob again to activate the dry-run protection.
 4. The main display appears.
 5. The 5-second timer is displayed and then counts down to 0 seconds.
 6. The display lights up blue and the symbol for dry-run protection is shown for 3 seconds.
- ✓ The dry-run protection is active.

↳ Status change

- While dry-run protection is active, the dry-run protection symbol is displayed in the menu.

12.1.2 Dry-run protection inactive

If dry-run protection is active, the motor can be switched on and off as required. Dry-run protection becomes inactive after the motor is switched off. Dry-run protection must be switched on again manually.

12.2 Dry-running detection

⚠ The pump begins to draw in air/gas.

- ✓ Dry running is successfully detected and the motor switches off immediately.

↳ Status change

- A message appears and the display turns yellow (code 09, see chapter 22).
- The note will be hidden automatically.

12.3 Switch off dry-run protection

The dry-run protection is automatically deactivated as soon as the motor is switched off. The dry-run protection can also be switched off during operation.

1. Press the rotary knob to open the menu.
 2. Press the rotary knob again to select the Dry-run protection.
 3. Press the rotary knob again to deactivate the dry-run protection.
- ✓ The dry-run protection is deactivated.

↳ Status change

- After deactivating the Dry-run protection, the symbol disappears from the menu.

13. Batch filling

Batch filling is an automated function that enables the predefined filling quantity to be filled. Once a profile has been successfully taught in learning mode, the quantity defined in it is filled reliably and precisely. Both the motor speed and the duration of the filling process are stored in up to six profiles.

These profiles can be loaded or overwritten at any time to flexibly select or adjust filling processes. Select Back to exit batch filling and return to the menu.

13.1 Start learning mode

1. Press the rotary knob to open the menu.
 2. Turn the knob to select batch filling and confirm by pressing.
 3. Press the rotary knob again to start learning mode.
- ✓ The learning mode is started.

↳ Status change

- The learning mode icon appears on the main display and flashes.
- The timer appears in the centre of the screen.

13.2 Teaching

1. Set the desired speed.
 2. Press the power button to start the learning process and start the engine.
 3. Fill the desired amount into a container.
 4. Press the power button to end the learning process and stop the motor.
- ✓ The training was successful.

↳ Status change

- The option to "Apply" or "Repeat" appears.

13.3 Confirm teaching

- Press the rotary knob to confirm the learning process.
- ✓ The teach-in process is complete.
- ✓ The filling process can now be repeated as often as required. See Filling.

↳ Status change

- The display turns green and the symbol for successful transfer appears.
- The main display appears and the filling symbol appears.

13.4 Repeat teaching

1. Turn the knob to repeat the process.
 2. Press the rotary knob to restart the learning mode.
- ✓ The repetition is initiated.

↳ Status change

- The "teaching" process is performed again.

13.5 Cancel teaching

1. Press the power button during the teach-in process (Chapter 13.2).
 2. Turn the knob until the back arrow appears.
 3. Press the rotary knob. Press the rotary knob again to cancel the learning mode.
- ✓ The learning mode has been terminated.

13.6 Save profile

1. Briefly press the power button to return to the menu.
 2. Turn the knob to access memory management and press to confirm.
 3. Press the rotary knob again to save the process.
 4. Select the desired profile (P1–P6) and confirm by pressing again.
- ✓ The desired profile is saved.

↳ Status change

- The main display appears.
- The saved profile is displayed on the main screen.

13.7 Overwrite profile

1. Briefly press the power button to return to the menu.
 2. Turn the knob to access memory management and confirm by pressing.
 3. Press the rotary knob again to overwrite the process.
 4. Select the desired profile (P1–P6) and confirm by pressing again.
- ✓ The profile will be overwritten.

↳ Status change

- The old profile is discarded and replaced by the new profile.

13.8 Load profile

1. Press the rotary knob to open the menu.
 2. Turn the knob to select batch filling and confirm by pressing.
 3. Turn the knob again to select memory management and confirm by pressing.
 4. Press the rotary knob again to access the profile selection.
 5. Turn the knob to select the desired profile (P1–P6) and confirm by pressing.
- ✓ The desired profile is being loaded.

↳ Status change

- The main display appears.
- The loaded profile is displayed on the main screen.

13.9 Fill

Once a profile has been successfully programmed or loaded, filling can begin.

1. After programming, press the power button to start filling.
2. The motor runs for the specified time and fills the liquid precisely.

↳ Status change

- The main display appears.
- The filling symbol is displayed on the main screen.
- The counter shows the number of filling operations performed.

14. Interface

The interface enables remote control of the motor. The motor can be switched on and off via the connected cable. In addition to the FLUXTRONIC®, external sensors can also be connected. The cable length should not exceed 3 m. Press Back to exit the interface and return to the menu.

14.1 Switch on interface

1. Press the rotary knob to open the menu.
 2. Turn the knob to select the interface.
 3. Press the rotary knob to switch on the interface.
- ✓ The interface is switched on.

↳ Status change

- The interface icon in the submenu changes the status to active.
- The interface icon is displayed on the main screen.

14.2 Switch off interface

1. Press the rotary knob to open the menu.
 2. Turn the knob to select the interface.
 4. Press the rotary knob to switch off the interface.
- ✓ The interface is switched off.

↳ Status change

- The interface icon in the submenu changes the status to inactive.
- The interface icon is hidden on the main display.

15. Lighting control

The Battery Motor has an LED lamp on the underside of the handle, which is used to illuminate the barrel. It can be switched on and off via the main menu. The light symbol is displayed or hidden on the main display depending on the status. Press Back to exit the light control and return to the menu.

15.1 Switch on the light

1. Press the rotary knob to open the menu.
 2. Turn the knob to select the light control.
 3. Press the rotary knob to switch on the light.
- ✓ The LED lamp is switched on.

↳ Status change

- The light symbol in the main menu changes the status to active.
- The light symbol appears on the main display.

15.2 Switch off the light

1. Press the rotary knob to open the menu.
 2. Turn the knob to select the light control.
 3. Press the rotary knob to switch off the light.
- ✓ The LED lamp is switched off.

↳ Status change

- The light symbol in the menu changes the status to inactive.
- The light symbol disappears from the main display.

16. Device information

System information can be accessed under Device Info. The software can be reset to factory settings under Software Reset. The Digital Documentation menu item allows you to display a QR code that leads directly to the corresponding digital documents. Select Back to exit Device Info and return to the menu.

Menu items

- System information
- Software reset
- Digital documentation
- Back

16.1 System information

Various statistics and details about the engine can be accessed under System Information. This includes the number of power-on cycles, operating hours, motor version (Core, Pro) and software version. Press the rotary knob again to exit the system information.

16.2 Call up system information

1. Press the rotary knob to open the menu.
 2. Turn the knob to select Device Info and press to confirm.
 3. Call up the system information by pressing again.
- ✓ The relevant data and statistics are shown on the display.

16.3 Software reset

Under "Software reset", all settings can be reset to the factory settings. This resets all parameters, deletes saved profiles, deactivates all programmes and resets the speed to 50%. All system information remains intact and is not deleted. Select Back to exit the Software reset area and return to the menu.

16.4 Perform a software reset

1. Press the rotary knob to open the menu.
 2. Turn the knob to select Device Info and press to confirm.
 3. Turn the knob to select "Software reset" and press to confirm.
 4. Press the rotary knob again to perform the software reset.
- ✓ The software reset was successfully completed.

↳ Status change

- The current submenu will close and you will return to the main display.

16.5 Cancel software reset

- The software reset can be cancelled by pressing "Back".

16.6 Digital documentation

Under "Digital documentation", a QR code is displayed that leads to the current operating instructions, the digital spare parts list and the engine service registration. Scan the code with your device to access the content.

Press the rotary knob to exit the view.

16.7 Access digital documentation

1. Press the rotary knob to open the menu.
 2. Turn the knob to select Device Info and press to confirm.
 3. Turn the knob to select the digital documentation and press to confirm.
- ✓ The QR code appears and can be scanned using a mobile device.

17. Temperature-performance adjustment

The motor is equipped with integrated temperature monitoring to ensure both safety and the service life of the device. The system automatically adjusts the power output as the motor temperature rises.

The temperature-performance adjustment is carried out in three stages:

Stage 1: Early warning

Triggering	Measure	Advertisement
20 K before reaching the maximum permissible temperature	Reduction of the current speed by 10%	Flashing thermometer symbol on the display

Stage 2: Critical temperature range

Triggering	Measure	Advertisement
10 K before reaching the permissible maximum temperature	Further reduction of the current speed by 10% (total 20%)	Yellow display background and thermometer icon still flashing

Stage 3: Overtemperature protection

Triggering	Measure	Advertisement
Reaching the permissible maximum temperature	Engine stop to prevent of damage	Red display background, warning symbol and thermometer symbol

Note

- ⚠ While temperature-based power adjustment is active, the speed cannot be increased, but it can be reduced at any time. As soon as the motor temperature leaves the critical range, the thermometer symbol and the coloured backlighting disappear. The motor then automatically returns to unrestricted normal operation.

18. Decommissioning

Once your liquid has been successfully transferred, you can begin decommissioning. Decommissioning is simple and involves minimal risk.

- ⚠ Before taking the device out of service, observe the safety instructions in Chapter 3.

18.1 Switch off

1. Switch off the motor by pressing the power button.
 2. The engine comes to a standstill.
 3. Remove the batteries from the device.
- ✓ The decommissioning process is complete.

- ⚠ If problems arise during decommissioning, remove the batteries from the motor and read the instructions again.

19. Disassembly

Once decommissioning has been completed, dismantling can begin.

- ⚠ Before dismantling, observe the safety instructions in Chapter 3.

19.1 Removing the engine

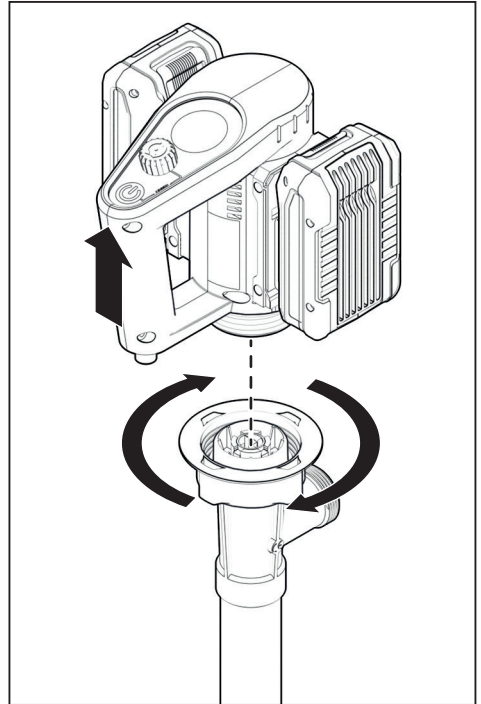

Once decommissioning is complete, the motor can be safely disconnected from the pump as described.

Step-by-step guide

1. Loosen the union nut on the pump.
 2. Remove the motor from the pump bearing flange.
- ✓ The dismantling of the engine is complete.

- ⚠ If problems arise during disassembly, stop immediately and read the instructions again.

19.2 Removing the batteries

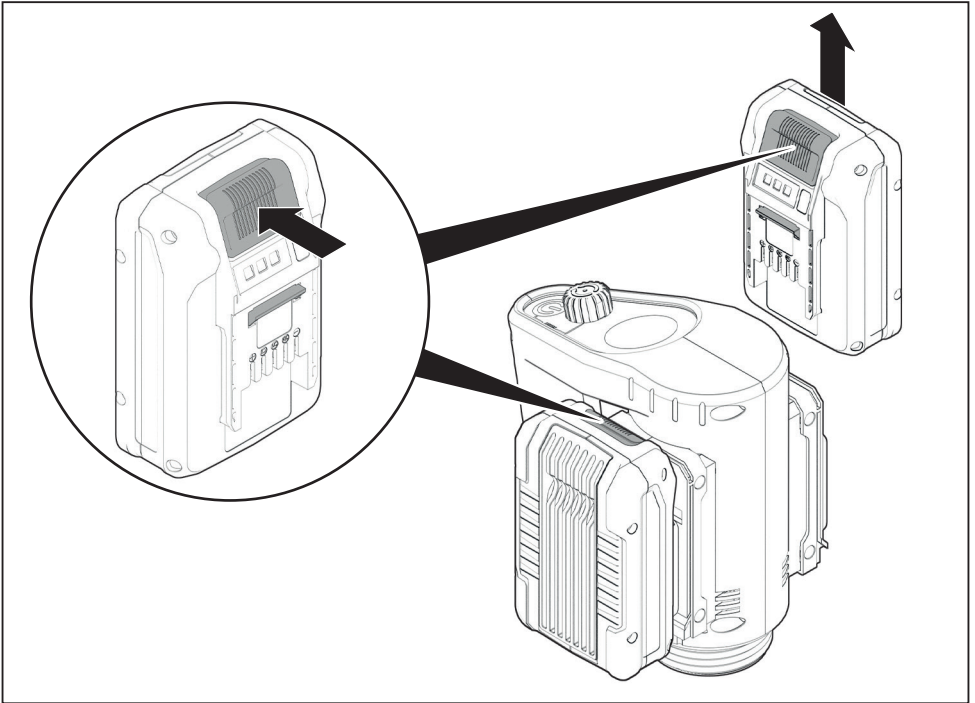

Once the motor has been successfully removed from the pump, the batteries can be removed according to the instructions.

Step-by-step guide

1. Press and hold the unlock button on the battery.
 2. Pull the battery upwards.
 3. Repeat on the other side.
- ✓ The removal of the batteries is complete.

⚠ If problems arise during disassembly, stop immediately and read the instructions again.

19.3 Removing the battery cover

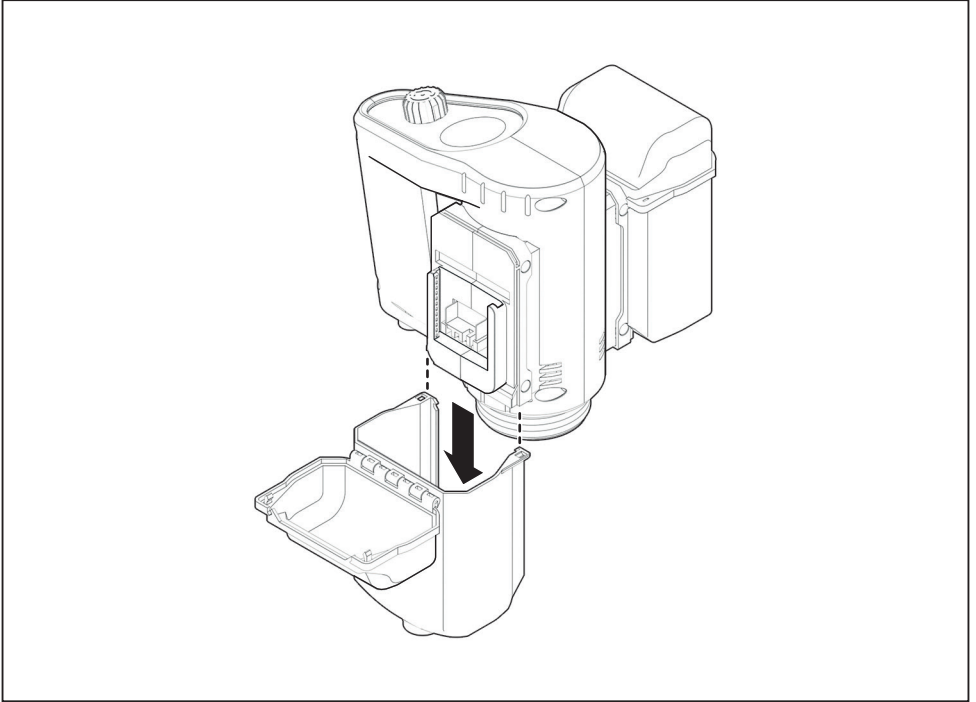

Step-by-step guide

1. Open the battery cover.
 2. Gently pull the battery cover apart at the top to unlock it.
 3. Pull the battery cover downwards.
 4. Repeat on the other side.
- ✓ The battery cover has been removed.

Note

- ⚠ Without the battery cover, there is no protection against splashing water!
- ⚠ The specified degree of protection is only achieved when the battery cover is fitted!
Ventilated housing: Rating IP24
Closed housing: Rating IP44
- ⚠ Rating according to DIN EN 60529.

20. Cleaning

Careful cleaning contributes significantly to the longevity and functional reliability of the motor. The motor should be cleaned regularly. FLUX recommends checking the motor for contamination after each use and cleaning it if necessary.

WARNING

EN-300 12

Safety during cleaning work!

Cleaning work with inserted batteries may cause an unwanted start.

- ▶ Always remove batteries before cleaning!

20.1 Cleaning the engine

1. Switch off the engine.
 2. Remove the motor from the pump.
 3. Remove both batteries from the motor.
 4. Moisten a cloth with cleaning agent.
 5. Clean the surface of the motor with a damp cloth.
 - The contact points on the motor must not come into contact with liquids!
 - Ensure that no liquid enters the ventilation slots!
 6. Dry the motor with a cloth.
 7. Ensure that there is no moisture left.
- ✓ The cleaned engine is ready for its next use or storage.

20.2 Cleaning the batteries

1. Moisten a cloth with cleaning agent.
 2. Clean the surface of the batteries with a damp cloth.
 - The contact points on the battery must not come into contact with liquids!
 3. Dry the batteries with a cloth.
 4. Ensure that there is no moisture left.
- ✓ The cleaned batteries are ready for their next use or storage.

21. Maintenance and repair

This chapter describes all necessary measures for care, inspection and maintenance. This ensures that the motor remains functional in the long term and that any potential faults can be detected and rectified at an early stage. Regular maintenance of the device is essential for safe and reliable operation.

WARNING

EN-300 13

Safety during maintenance work!

Maintenance work with batteries in use may cause an unintended start.

- ▶ Always remove batteries before performing any maintenance work!

21.1 Preparation

1. Switch off the engine.
 2. Remove the motor from the pump.
 3. Open the battery cover
 4. Remove both batteries from the motor.
 5. Remove the battery cover.
- ✓ The preparation is complete.





21.2 Maintenance

- Regularly check the motor for full functionality.
- Regularly check the motor for external damage.
- Regularly check the condition of wear parts.
- Check the condition of the batteries regularly.

21.3 Repair

Repairs to the engine may only be carried out by trained specialists!

For more extensive repairs, please return the motor to FLUX. To do so, use the RMA process as described in section 1.3.

-  Do not open the batteries!
-  The batteries must not be repaired!
-  Defective or damaged batteries must be replaced!
-  Only use original spare parts for repairs.

22. Troubleshooting

Code	Error description	Solution	Category
01	Engine inactive 24 V external power 2.4 W exceeded	Restart engine	Operating error
02	Engine inactive Temperature exceeded (MOSFET)	Restart engine	Operating error
03	Engine inactive Temperature exceeded (engine)	Restart engine	Operating error
04	Motorcycle cycle interrupted Motor current too high	Restart engine	Operating error
05	Engine inactive Battery voltage too high (left)	Restart engine	System error
06	Engine inactive Battery voltage too high (right)	Restart engine	System error
07	Engine inactive Battery voltage too low (left)	Restart engine	System error
08	Engine inactive Battery voltage too low (right)	Restart engine	System error
09	Engine inactive Dry running	Restart engine	Note
10	Engine inactive Rotary knob defective	Request a return (RMA)	Defect
11	Engine inactive Power button defective	Request a return (RMA)	Defect
14	Low load current The motor operates with almost no load or not at all (motor controller)	Restart engine	System error
15	excessive temperature The device has overheated. Undervoltage (gate driver) The control electronics are receiving insufficient voltage Logic fault (Hall signals) motor controller The motor's position sensors are reporting incorrect values	Restart engine	System error
16	Short to ground A cable or component is damaged Short to supply A cable or component is damaged Short-circuited motor winding Motor controller Wires have come into contact with each other in the motor.	Request a return (RMA)	Defect
17	Engine inactive Teaching process for dry-run protection not Possible. Motor current fluctuates too much	Improve system stability (reduce power fluctuations)	Operating error

23. Recycling



Products marked with a crossed-out wheelie bin must not be disposed of in the general waste. The motor must be disposed of properly at a recycling centre for old electrical appliances.



Lithium-ion batteries must be disposed of at collection points for rechargeable and non-rechargeable batteries. It is prohibited to dispose of batteries in residual waste or in the environment!



The packaging is 100% recyclable. The box is made of corrugated cardboard. The packaging must be disposed of in the waste paper bin.



The operating instructions are 100% recyclable and made of paper. The operating instructions may only be disposed of in the waste paper after the product has been disposed of.

23.1 Preparation

1. Switch off the engine.
 2. Remove the motor from the pump.
 3. Remove both batteries from the motor.
 4. Remove the battery cover.
- ✓ The preparation is complete.

23.2 Disposal

- Dispose of waste and parts that cannot be repaired or reused in an environmentally friendly manner.
- Dispose of plastic, rubber and metals separately.
- Engine at the recycling centre for electrical appliance disposal.
- The motor can optionally be returned to FLUX.

Note

- ⚠ Dispose of contaminated parts in an environmentally friendly manner.
- ⚠ Dispose of batteries at battery collection points.
- ⚠ Observe the applicable regulations and laws regarding the disposal of goods.

24. EU Standards

IP24 The ventilated motor meets the requirements of rating IP24 in accordance with DIN N 60529. The device is therefore protected against the ingress of solid foreign bodies with a diameter ≥ 12.5 mm and against splashing water from all directions.

This rating only applies when the battery cover is fully assembled guaranteed.

IP44 The enclosed motor meets the requirements of rating IP44 in accordance with DIN EN 60529. The device is therefore protected against the ingress of solid foreign bodies with a diameter ≥ 1.0 mm and against splashing water from all directions.

This rating is only guaranteed when the battery cover is fully assembled.

25. EU Directives

CE The motor has been tested in accordance with EU directives and bears the CE mark. FLUX thus ensures compliance with the requirements for safety, health protection and environmental protection in accordance with EU directives.

For further details, please refer to the EU Declaration of Conformity in the appendix.

EMC The motor complies with the requirements for electromagnetic compatibility (EMC) in accordance with the applicable EU directives.

FLUX thus ensures that the device neither causes nor is affected by unacceptable electromagnetic interference. The motor bears the EMC symbol accordingly.

25.1 EU Declaration of Conformity

FLUX-GERÄTE GMBH
Talweg 12 · D-75433 Maulbronn



**EU Konformitätserklärung
EU Declaration of Conformity
Déclaration de Conformité UE**

Hiermit erklären wir,
We, **FLUX-GERÄTE GMBH, Talweg 12, 75433 Maulbronn**
Nous,

dass das nachfolgend bezeichnete Produkt aufgrund seiner Konzipierung und Bauart sowie in der von uns in Verkehr gebrachten Ausführung den einschlägigen grundlegenden Sicherheits- und Gesundheitsanforderungen der EG - Richtlinie entspricht. Bei einer nicht mit uns abgestimmten Änderung des Produktes verliert diese Erklärung ihre Gültigkeit.

hereby declare that the following designated product complies with the pertinent fundamental safety and health requirements of the EC Directive in terms of its design and construction and in terms of the version marketed by us. This declaration loses its validity in the event of a modification to the product not agreed with us.

déclarons par la présente que le produit désigné ci-après répond aux exigences fondamentales courantes en matière de sécurité et de santé de la directive CE aussi bien sur le plan de sa conception et de son type de construction que dans la version mise en circulation par nos soins. Cette déclaration perd sa validité en cas de modification du produit que nous n'avons pas approuvée.

Bezeichnung des Produktes: Akku-Motor
Description of the product: Battery motor
Désignation du produit : Moteur à accumulateur
Serien - Nr.: siehe Typenschild am Gerät
Serial no.: refer to nameplate on the device
N° de série : voir plaque signalétique sur l'appareil

Bevollmächtigter für die Zusammenstellung der Technischen Unterlagen: Klaus Bräuner, FLUX-GERÄTE GMBH,
Authorised person for the compilation of the technical documents: Talweg 12
Mandataire pour la constitution du dossier technique: 75433 Maulbronn

Qualitätsmanagementsystem: ISO 9001
Quality Management system:
Système de management de la qualité :

Eingehaltene Richtlinien	Maschinenrichtlinie 2006/42/EG	EMV Richtlinie 2014/30/EU	Richtlinie RoHS 2011/65/EU
Pertinent Directives	EC Machinery Directive 2006/42/EC	EMV Directive 2014/30/EU	Directive RoHS 2011/65/EU
Directives courantes	Directive CE Machines 2006/42/CE	EMV Directive 2014/30/UE	Directive RoHS 2011/65/UE
Angewandte harmonisierte Normen: Applied harmonised standards, in particular: Normes harmonisées appliquées en particulier :	EN ISO 12100:2010	EN IEC 61000-6-2:2019	EN IEC 61000-6-4:2019
FBM 4100	x	x	x

Datum / Hersteller - Unterschrift:
Angaben zum Unterzeichner
Date / manufacturer – signature
Details of the signatory:
Date / Signature du fabricant
Renseignements du signataire :

10.12.2025 / FLUX-GERÄTE GMBH
Klaus Hahn
Geschäftsführer / Managing Director / Directeur

10-95460838_00_1225



FLUX-GERÄTE GMBH

Talweg 12
75433 Maulbronn
Germany

Tel.: +49 (0)7043 101-0
Fax: +49 (0)7043 101-555
Email: export@flux-pumpen.de

www.flux-pumps.com

Subject to technical changes.

Copyright © 2026 FLUX GERÄTE-GMBH.
All rights reserved.

DOWNLOAD CENTER

Current digital operating instructions.
Registration required.

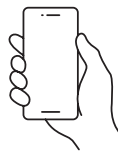

Follow us!

